User's and Service Guide

HP 87050A
Option H08
Multiport Test Set

HP part number: 87050-90004
Printed in USA April 1997

Notice

The information contained in this document is subject to change without notice.

Hewlett-Packard makes no warranty of any kind with regard to this material, including but not limited to, the implied warranties of merchantability and fitness for a particular purpose. Hewlett-Packard shall not be liable for errors contained herein or for incidental or consequential damages in connection with the furnishing, performance, or use of this material.

**Safety and Regulatory
Information**

For safety and regulatory information see Chapter 7.

© Copyright Hewlett-Packard Company 1995, 1997
All Rights Reserved. Reproduction, adaptation, or translation without prior written permission is prohibited, except as allowed under the copyright laws.
1400 Fountaingrove Parkway, Santa Rosa, CA 95403-1799, USA

HP 87050A Option H08 Multiport Test Set

The HP 87050A Option H08 Multiport Test Set is designed for use with Hewlett-Packard 50 Ω network analyzers such as the HP 8753D, HP 8711B, HP 8712B, HP 8713B, and HP 8714B.

The test set provides single-connection measurements of multiport devices with up to eight ports, such as distribution amplifiers, taps, switches and couplers. Throughput is increased by reducing the number of device reconnects the operator must perform. Switching is performed by using mechanical switches.

The test set can be controlled with the network analyzer's internal IBASIC capability (if available), an external HP-IB controller, or parallel control.

NOTE

This *User's Guide* documents the use of the test set with an HP 8753D.

— |

| —

— |

| —

Contents

1. Installing the Test Set	
Step 1. Check the Shipment	1-3
Step 2. Meet Electrical and Environmental Requirements	1-4
2. Getting Started	
Connecting and Turning on the Test Set	2-3
Setting the Test Set Address Switch	2-4
Performing the Operator's Check	2-5
Description	2-5
Equipment Required	2-5
Procedure	2-6
3. Controlling the Test Set and Making Measurements	
Control Bits	3-3
Commands	3-4
Calibrating the Test System	3-9
Making Measurements	3-11
Measuring Transmission	3-12
Measuring Reflection	3-14
Example Programs	3-15
The "CONTROL" Program	3-15
4. Front/Rear Panel	
Front Panel	4-3
Line Power Switch	4-4
Ports 1—8	4-4
The REFLECTION Connector	4-5
The TRANSMISSION Connector	4-5
The GROUND Connector	4-5
The PORT CONNECTION Status LEDs	4-6
Rear Panel	4-7
The PARALLEL PORT INPUT Connector	4-8
The PARALLEL PORT OUTPUT Connector	4-8
The PRINTER/TEST SET Switch	4-8
HP-IB Connector	4-8
Address Switch	4-9

Line Module	4-9
The Line Fuse	4-11
5. Specifications	
Specifications and Characteristics	5-3
General Characteristics	5-4
Environmental Characteristics	5-4
Hewlett-Packard Sales and Service Offices	5-6
HP 87050A Option H08 Options	5-6
6. Service	
Performance Tests	6-3
Insertion Loss	6-3
Return Loss	6-5
Isolation	6-6
Switch Repeatability	6-7
Performance Test Record	6-8
Adjustments	6-16
Troubleshooting and Block Diagram	6-17
General Troubleshooting Notes	6-17
Troubleshooting Power Supply Problems	6-17
Troubleshooting the Front Panel Board	6-18
Troubleshooting the Controller and Switch Driver Boards	6-18
Block Diagrams	6-20
Theory of Operation	6-22
System Theory	6-22
A1 Power Supply Theory	6-22
A2 Front Panel Display Theory	6-23
A3 Controller (Motherboard) and Switch Driver (Daughterboard) Board Theory	6-23
Replaceable Parts and Post-Repair Procedures	6-25
Connector Replacement	6-28
7. Safety and Regulatory Information	
Safety Information	7-3
Warnings	7-3
Cautions	7-5
Statement of Compliance	7-6
Cleaning Instructions	7-6
Shipping Instructions	7-6
Instrument Markings	7-7

Regulatory Information 7-8
 Notice for Germany: Noise Declaration 7-8
 Declaration of Conformity 7-9

Index

Figures

1-1. Protective Earth Ground	1-5
1-2. Ventilation Clearance Requirements	1-6
2-1. Connecting the Test Set to the Network Analyzer	2-3
2-2. The Test Set Address Switch	2-4
3-1. Eight Control Bits	3-3
3-2. Controlling the Test Set Over HP-IB	3-6
3-3. Calibrating the Test System	3-9
3-4. Controlling the Test Set	3-13
4-1. Front Panel Features	4-3
4-2. Physical Description of Type-N Connector	4-4
4-3. Rear Panel Features	4-7
4-4. Power Cable and Line (Mains) Plug Part Numbers	4-10
4-5. Location of Line Fuses	4-11
6-1. HP 87050A-H08 Block Diagram for Serial Numbers US 36130100—US 36130121	6-20
6-2. HP 87050A-H08 Block Diagram for Serial Numbers US 36130122 and above	6-21

Tables

1-1. HP 87050A Option H08 Accessories Supplied	1-3
3-1. Test Port Addresses	3-7
5-1. 87050A Specifications	5-3
5-2. Hewlett-Packard Sales and Service Offices	5-7
6-1. Insertion Loss Specifications	6-4
6-2. Return Loss Specifications	6-5
6-3. Replaceable Parts and Post-Repair Procedures	6-26

Installing the Test Set

Installing the Test Set

This chapter will guide you through the steps necessary to correctly and safely install your multiport test set. The steps are:

1. Check the shipment
2. Meet electrical and environmental requirements

Step 1. Check the Shipment

After you have unpacked your test set, it is recommended that you keep the packaging materials so they may be used if your instrument should need to be returned for maintenance or repair.

Check the items received against Table 1-1 to make sure that you received everything.

Inspect the test set and all accessories for any signs of damage that may have occurred during shipment. If your test set or any accessories appear to be damaged or missing, call your nearest Hewlett-Packard Sales or Service office. Refer to Table 5-2 in Chapter 5 for the nearest office.

Table 1-1. HP 87050A Option H08 Accessories Supplied

Description	Quantity	HP Part Number
Power Cord	1	See Figure 4-4
Type-N Flexible Jumper Cables	2	8120-6995
Parallel Port Interface Cable	1	08711-60123
Example Program Disk	1	87050-10011
HP 87050A Option H08 User's Guide	1	87050-90004
APC-7 to Type N I/F	2	85054-60001

Step 2. Meet Electrical and Environmental Requirements

1. The line power module on your test set is an autoranging input. It is designed to be used with an ac power source with a nominal voltage of either 115 V or 230 V.
2. Ensure the available ac power source meets the following requirements:
90 to 250 Vac, 48 to 66 Hz, 55 VA

CAUTION

This product has autoranging line voltage input. Be sure the supply voltage is within the specified range.

If the ac line voltage does not fall within these ranges, an autotransformer that provides third wire continuity to earth ground should be used.

3. Ensure the operating environment meets the following requirements for safety:
 - indoor use
 - altitude up to 15,000 feet (4,572 meters)
 - temperature 0 °C to 55 °C
 - maximum relative humidity 80% for temperatures up to 31 °C decreasing linearly to 50% relative humidity at 40 °C
 - use only in INSTALLATION CATEGORY II, and POLLUTION DEGREE 2, per IEC 101 and 664 respectively
4. Verify that the power cable is not damaged, and that the power source outlet provides a protective earth ground contact. Note that the following illustration depicts only one type of power source outlet. Refer to Figure 4-4 to see the different types of power cord plugs that can be used with your test set.

Step 2. Meet Electrical and Environmental Requirements

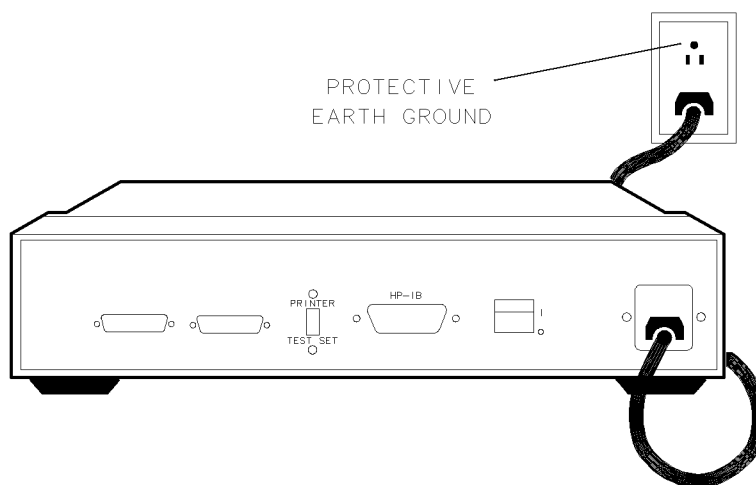

pr63b

Figure 1-1. Protective Earth Ground

WARNING

This is a Safety Class I product (provided with a protective earthing ground incorporated in the power cord). The mains plug shall only be inserted in a socket outlet provided with a protective earth contact. Any interruption of the protective conductor, inside or outside the instrument, is likely to make the instrument dangerous. Intentional interruption is prohibited.

5. Ensure there are at least two inches of clearance around the sides and back of the test set or the system cabinet.

Installing the Test Set

Step 2. Meet Electrical and Environmental Requirements

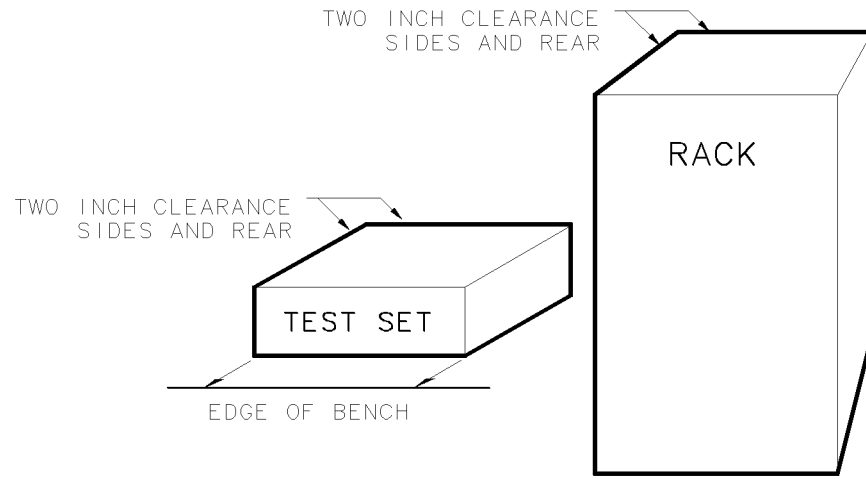

pr64b

Figure 1-2. Ventilation Clearance Requirements

Step 2. Meet Electrical and Environmental Requirements

6. Set up a static-safe workstation. Electrostatic discharge (ESD) can damage or destroy components.

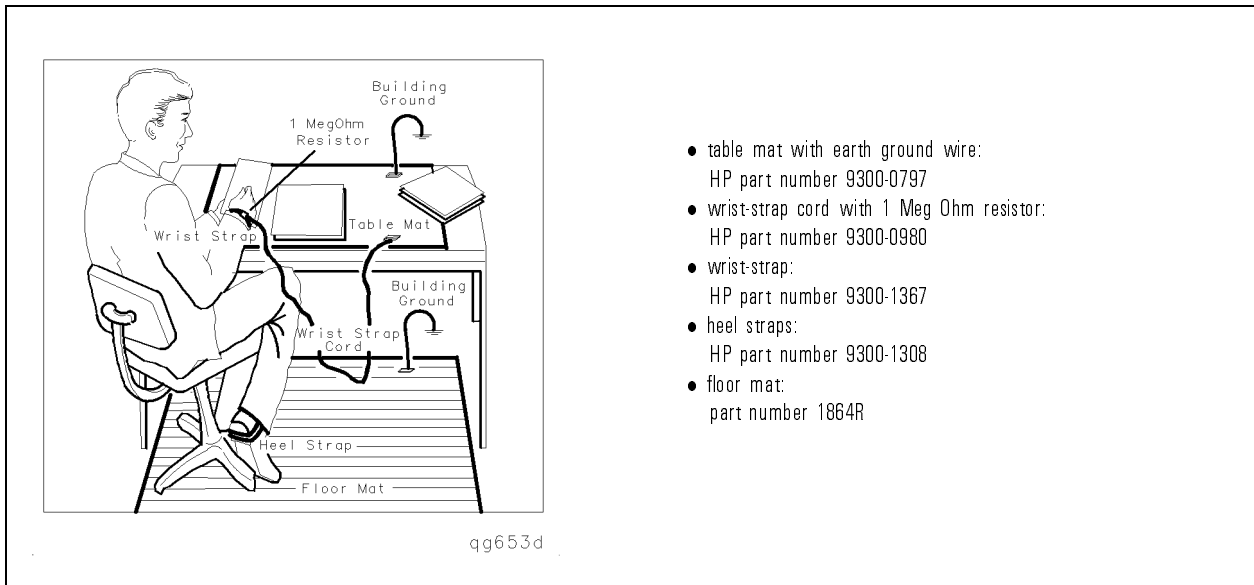

Installing the Test Set

Step 2. Meet Electrical and Environmental Requirements

Getting Started

Getting Started

Connecting and Turning on the Test Set

The test set is designed to be placed underneath the network analyzer in a rack system and connected to it as shown in Figure 2-1. Use the two type-N 50 Ω jumper cables that were shipped with the test set. See Table 1-1.

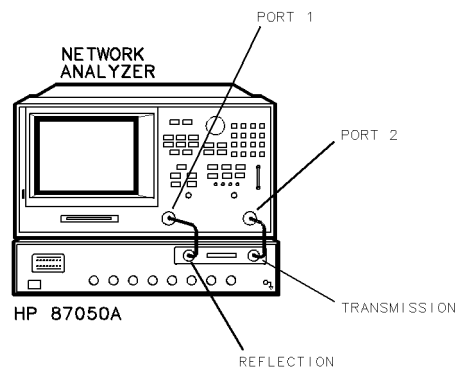

pt613a

Figure 2-1. Connecting the Test Set to the Network Analyzer

After all the proper connections have been made, turn on the test set using the front panel line switch.

Setting the Test Set Address Switch

The test set is shipped with the HP-IB address set to 12, which sets the parallel address to 00 as in Figure 2-2. Refer to Chapter 3, "Controlling the Test Set and Making Measurements," for the definition of the parallel address.

To set the HP-IB address, set all five switches so that the sum of the switches in the on or "1" position equal the desired address. In the example below, the two switches in the "on" position are 8 and 4, thus the HP-IB address of 12.

To set the parallel address, use only the number 1 and 2 switches. The possibilities for parallel port addressing are an address of 0, 1, 2, or 3.

When HP-IB is used, the parallel address is ignored.

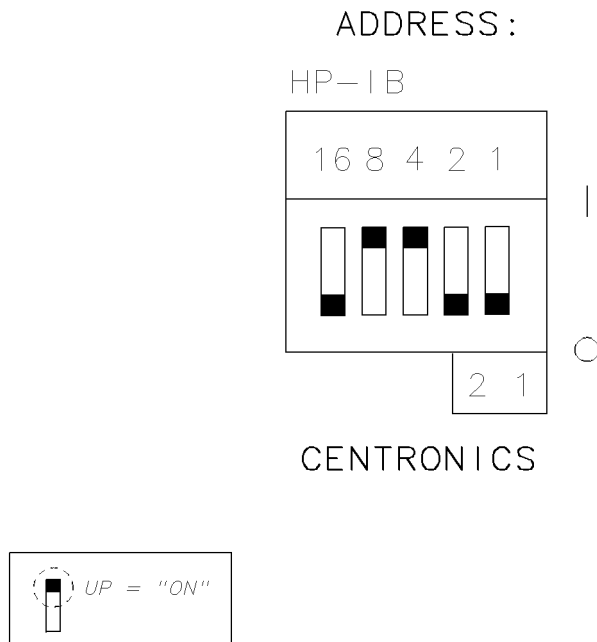

pr66b

Figure 2-2. The Test Set Address Switch

Performing the Operator's Check

NOTE

For information on how to control the test set, refer to Chapter 3.

Description

The following operator's check is designed to provide you with a high degree of confidence that your test set is working properly. It is *not* designed to verify specifications. To verify specifications, refer to Chapter 6.

Equipment Required

- Network analyzer, 50 Ω impedance (HP 8753D)
- Computer (HP 9000 series 200/300/700)
- "CONTROL" program (part of HP part number 87050-10011; included with each HP 87050A). See "Example Programs" in Chapter 3.
- Cable, 50 Ω Type-N, (HP part number 8120-4781 or equivalent)
- Calibration Kit, 50 Ω (HP 85032B)
- APC-7 to Type N Adapter; (HP part number 85054-60001)

Procedure

1. Perform a one-port reflection calibration at the end of a 50 Ω cable over the frequency range of 300 kHz to 6 GHz on the analyzer. Verify the calibration is active and that the unterminated (or shorted) cable displays a return loss of 0 ± 0.2 dB.
2. Connect the cable (already connected to the reflection port of the analyzer) to the reflection port of the HP 87050A test set.
3. Measure the return loss of each section of the test set by selecting ports 1 through 8 — one at a time — by using the “CONTROL” example program and viewing the display on the analyzer. All four ports should be either unterminated or shorted.
4. The return loss value should be > -12 dB (the absolute value should be smaller than 12). This accounts for the maximum of 2 dB loss each way, plus a 2 dB margin of error to account for source match errors. Typically the return loss for each port will equal about -4 to -8 dB, depending upon frequency, and all ports should look approximately the same.
5. Better accuracy can be obtained by averaging two measurements; one taken with a short attached and one taken with an open attached.

If a more complete test is desired, repeat the above procedure, but this time terminate each port being tested with a known good 50 Ω load (better than -40 dB). The resulting return loss should be better than -13 dB (the absolute value should be greater than 13.)

Please note that this is an 80% confidence test only. A unit could pass this simple test and yet still not function properly. For more complete testing, see “Performance Tests” in Chapter 6.

**Controlling the Test Set
and Making Measurements**

Controlling the Test Set and Making Measurements

The HP 87050A Option H08 is a “slave” instrument: a controller must be used to control the test set. The controller can talk to the network analyzer via HP-IB, which then controls the test set via the parallel connection, or the controller can control the test set directly via HP-IB, or a controller equipped with a parallel connection can control the test set directly.

An example program listing is provided at the end of this chapter.

Control Bits

Eight control bits are required to write to the test set:

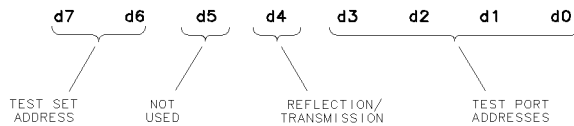

pr67b

Figure 3-1. Eight Control Bits

Test Set Address	These 2 bits allow for up to 4 test sets to be addressed from the parallel port connector of the network analyzer. Test set addresses are set with a rear panel switch on the test set. These 2 bits are ignored when HP-IB is used.
Not Used	This bit may be used for future customization. It must be set to zero.
Reflection/ Transmission	This bit selects which input port of the test set is to be connected. “0” selects reflection as active, “1” selects transmission.
Test Port Addresses	These 4 bits select which port of the test set is connected to the active input port.

Commands

As mentioned earlier, the test set can be controlled in two ways. The first way is to write HP-IB commands to the network analyzer which then writes to the test set via the parallel port. See Figure 3-4 for a diagram of connections for this type of control. The second way is to write HP-IB commands directly to the test set's HP-IB port. Both of the following examples use the variable "D" which is defined in Table 3-1, and composed from Figure 3-1.

To use a parallel port connection with the HP 8753D, use an HP-IB command to write bits on the parallel port. The following example assumes that the address of the network analyzer is 16.

```
OUTPUT 716;"PARALGPIO;" Sets the parallel port for GP-IO function
OUTPUT 716;"PARAOUT[D];" Programs all GP-IO output bits (0 to 256)
                           at once
```

To address the HP 87050A Option H08 test set directly over HP-IB, use a controller to write directly to the test set's HP-IB port. The following example assumes that the address of the test set is 12.

```
OUTPUT 712;CHR$( [D] );
```

NOTE

Be sure to include the ending semicolon.

If using Quick basic or Visual Basic be sure to disable EOI and EOL before sending commands to the test set. Including the semicolon will not ensure that these commands are disabled as would be the case in HP Basic/RMB. Using the HP 82335 HP-IB Interface and Visual Basic, the following commands will disable the EOI, EOL, send the necessary data to the test set, and re-enable EOI and EOL. Be sure to re-enable EOI and EOL before sending data to another instrument.

```
HpibEoi(hHpib;7,0) 'disable EOI
```

```
HpibEol(hHpib;7, "",0) 'disable EOL
```

```
HpibOutput(hHpib;712,chr$([D])) 'send command to test set
```

```
HpibEol(hHpib;7,chr$(13)+chr$(10),2) 're-enable EOL and set to  
'chr$(13)+chr$(10)
```

```
HpibEoi(hHpib;7,1,) 're-enable EOI
```

where hHpib specifies the handle returned by HpibOpen

For more information on the EOI and EOL commands refer to the programming library manual supplied with the HP 82335 interface.

Controlling the Test Set
and Making Measurements

Commands

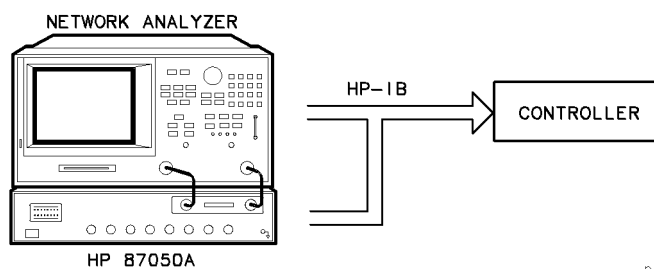

Figure 3-2. Controlling the Test Set Over HP-IB

NOTE

Connection to the network analyzer is not required when controlling the test set over HP-IB.

Table 3-1. Test Port Addresses

Connection	d7 d6 ¹	d5 ... d0 ²	D
Reflection to Port 1	00	000000	0
Reflection to Port 2	00	000001	1
Reflection to Port 3	00	000010	2
Reflection to Port 4	00	000011	3
Reflection to Port 5	00	000100	4
Reflection to Port 6	00	000101	5
Reflection to Port 7	00	000110	6
Reflection to Port 8	00	000111	7
Transmission to Port 1	00	010000	16
Transmission to Port 2	00	010001	17
Transmission to Port 3	00	010010	18
Transmission to Port 4	00	010011	19
Transmission to Port 5	00	010100	20
Transmission to Port 6	00	010101	21
Transmission to Port 7	00	010110	22
Transmission to Port 8	00	010111	23

¹ These 2 bits are used for parallel port addressing and are ignored when HP-IB is used. See "Setting the Test Set Address Switch" in Chapter 2.

² See Figure 3-1 for an explanation of these bits.

An easy way to remember these numbers is:

$$\text{Reflection} = \text{Port Number} - 1$$

$$\text{Transmission} = \text{Port Number} + 15$$

For example, to connect Port 3 to Reflection, the "D" number is 2, (3 - 1). To connect Port 3 to Transmission the "D" number is 18, (3 + 15).

Controlling the Test Set
and Making Measurements

Commands

NOTE

When a test set port is not in use (not connected to transmission or reflection) it is terminated in 50 Ω .

Calibrating the Test System

After the test set has warmed up, you should calibrate before making measurements. Refer to your network analyzer's *User's Guide* to determine the type of calibration appropriate for the measurements you will be making.

You will need to calibrate each measurement path separately and store the calibration as an instrument state in the network analyzer. Refer to your network analyzer's *User's Guide* for information on how to calibrate and store instrument states.

Refer to Figure 3-3. In this example setup the following tests will be made:

- Return Loss on the DUT's input and 2 output ports (A and B)
- Insertion Loss (or gain) between the DUT's input and port A
- Insertion Loss (or gain) between the DUT's input and port B

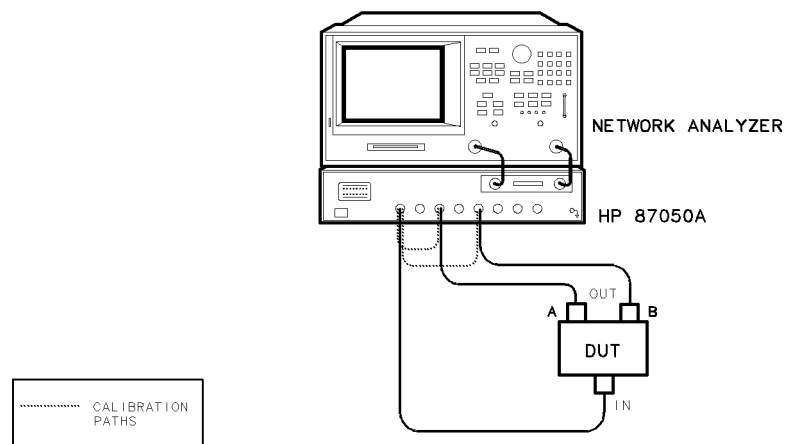

Figure 3-3. Calibrating the Test System

Controlling the Test Set
and Making Measurements

Calibrating the Test System

For the best accuracy, you should perform a full two-port calibration between test set ports 1 & 3, and again between ports 1 & 5. As mentioned above, you need to save the calibrations as instrument states. See your analyzer's *User's Guide* for information on calibrations and saving instrument states.

CAUTION

When performing a full two-port calibration and making subsequent measurements, you must use the transfer switch internal to the HP 8753D to change the RF signal path direction. Do not use the test set to change the RF signal path direction when you are using a full two-port calibration. Doing so will render the calibration invalid.

Making Measurements

The following examples assume that you are using a parallel port connection with an HP 8753D, with the test set's parallel address set to "0". See "Setting the Test Set Address Switch" in Chapter 2 for information on setting the test set's address.

NOTE

The HP 87050A Option H08 can only receive a single command every 75 ms. this reduces the risk of damaging the mechanical switches.

Measuring Transmission

Refer to Figure 3-4 for the following discussion. With the HP 8753D set to measure forward transmission (S_{21}), the analyzer's RF source is being output through the analyzer's PORT 1, and PORT 2 is set to receive the RF signal.

By using the following commands, you will connect PORT 3 of the test set to the REFLECTION port, and you will connect PORT 8 of the test set to the TRANSMISSION port. You will thus be measuring forward transmission through the device under test when measuring S_{21} . This will provide you with gain or insertion loss information.

```
OUTPUT 716;"PARALGPIO;"  
OUTPUT 716;"PARAOUT2;"
```

```
OUTPUT 716;"PARALGPIO;"  
OUTPUT 716;"PARAOUT23;"
```

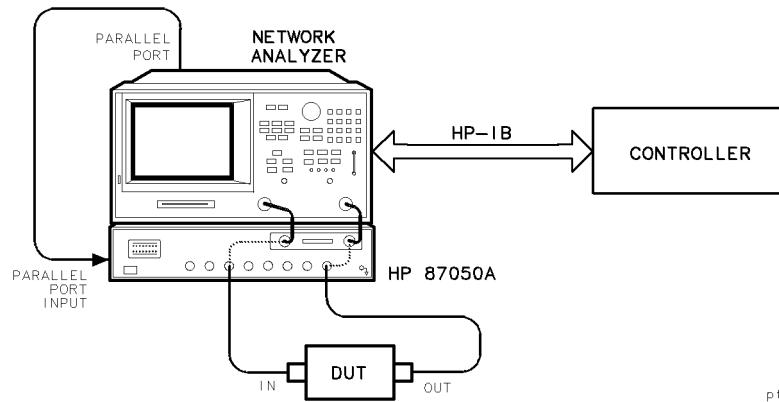

pt614a

Figure 3-4. Controlling the Test Set

Measuring Reflection

By leaving the DUT connected as in Figure 3-4 and setting the network analyzer to measure S_{11} , you can measure reflection or return loss.

Example Programs

Two example programs are included on the example programs disk (HP part number 87050-10011) provided with each test set. These programs are written in HP BASIC and are for use with an HP 9000 series 200/300/700 computer. The two programs are briefly described below and the "CONTROL" program is listed following the descriptions.

- CONTROL** A program that demonstrates the control of the HP 87050A via HP-IB and/or the parallel port. This program can be used to manually select any port combination.
- CYCLE** This program prompts the user to make an S_{11} one-port call on the HP 8753D and then cycles through all eight test set ports, pausing at each one, so that the user can view the return loss of each port.

The "CONTROL" Program

The "CONTROL" program (listed below) will first ask the user which method will be used to control the HP 87050A; either HP-IB or parallel port. It will then ask which ports are to be enabled. The port entries are done in pairs; two numbers separated by commas. The numbers may range from 0 through 8. For example, the entry of "2,5" will connect the REFLECTION port to PORT 2 and the TRANSMISSION port to PORT 5. The program is a continuous loop. Press STOP to end program execution.

```
10      ! CONTROL: This example program allows "manual" control of
the HP 87050A
20      !           via the parallel port of the HP 8753D or via HP-IB
directly.
30      !
40      !   NOTE: You MUST select either HP-IB control or Parallel
Port control.
50      !           If Parallel Port via the HP 8753D is selected, this
program will
```

Controlling the Test Set
and Making Measurements

Example Programs

```
60      !           return the analyzer to LOCAL control after the
switches are set.
70      !           Set HP-IB address as required below.
80      !           HP 87050 can be set to one of 8 Parallel Port
addresses.  This
90      !           program (SUB Set_switches) assumes it is set to
address 00.
100     !
110     ! Copyright:  Hewlett-Packard Co. Palo Alto, CA 94304
120     !           Part of HP P/N 87050-10011
130     !           Developed at Microwave Instruments Division
Santa Rosa, CA
140     !           Revision A.01.00   15 April 1996   RD
150     !
160     Nwa_addr=716 ! 8753D HP-IB ADDRESS  (IF USED)
170     Ts_addr=712  ! 87050 HP-IB ADDRESS  (IF USED)
180     !
190     !
200     CLEAR SCREEN
210     PRINT USING "3/,K,/","*** DEMONSTRATION PROGRAM FOR 87050A
MANUAL CONTROL ***"
220     PRINT "Either direct HP-IB control to the 87050 may be
selected (H), or"
230     PRINT "indirect control via the Parallel Port (P) of the
8753D."
240     REPEAT
250         Answ$="P"
260         OUTPUT 2;Answ$&CHR$(255)&"H";
270         BEEP 300,.1
280         INPUT "Select desired test-set control.  HP-IB or
Parallel Port? (Enter H or P)",Answ$
290         Answ$=UPC$(Answ$[1,1])
300     UNTIL Answ$="P" OR Answ$="H"
310     Controller$=Answ$
320     !
330     ABORT 7
340     CLEAR SCREEN
350     IF Controller$="P" THEN
360         Addr=Nwa_addr           ! Assign address to the analyzer
370         PRINT "Test set is being controlled via Parallel Port;
8753D HP-IB address =";Addr
```

Example Programs

```
380 ELSE
390     Addr=Ts_addr
400     CLEAR Addr
410     PRINT "Test set is being controlled directly via HP-IB.
HP-IB address =";Addr
420 END IF
430   Isc=Addr DIV 100 ! Interface Select Code
440   !
450   PRINT USING "/,K,/";RPT$("-",77)
460   PRINT "For manual operation of this switch box, enter TWO
numbers separated by a"
470   PRINT "comma (,). The two numbers represent the Reflection
port and Transmission"
480   PRINT "port to be used (respectively"
490   PRINT "These two values cannot be
the same."
510   PRINT "To terminate program, press STOP or PAUSE"
520   PRINT
530   PRINT "Example: 2,3 sets the switch box Reflection to
Port 2 and Transmission to"
540   PRINT "Port 3. 4,0 sets Reflection port to Port 4;
Transmission is not used."
550   LOOP
560     LOOP ! Enter port numbers here
570       Refl=0
580       Trans=0
590       BEEP 500,.1
600       INPUT "Enter the Refl/Trans Port selections separated
by commas: e.g. 2,4",Refl,Trans
610       Refl=INT(Refl)
620       Trans=INT(Trans)
630       EXIT IF (Refl=Trans OR (Refl=0 AND Trans=0)) AND
Refl<9 AND Trans<9 AND Refl>=0 AND Trans>=0
640       DISP "Port selections MUST be different if non-zero;
Range= 1 to 8. Try again!"
650       BEEP 1500,.3
660       WAIT 2
670     END LOOP
680     Set_switches(Addr,"REFL",VAL$(Refl),Controller$) ! Sets
Reflection Port
690     Set_switches(Addr,"TRANS",VAL$(Trans),Controller$) ! Sets
```

Controlling the Test Set
and Making Measurements

Example Programs

```
Transmission Port
700     PRINT TABXY(1,16),"Current Reflection Port  =";Refl
710     PRINT TABXY(1,17),"Current Transmission Port =";Trans
720     LOCAL Isc
730     END LOOP
740     END
750     !
760     SUB Set_switches(Addr,Main_port$,Switched_port$,Controller$)
770
=====
780     !  PURPOSE: To set the 87050A H08 switches.
790
!-----
800     !
810     !  PARAMETERS :
820     !
830     !  Controller$      [P|H]   P= Parallel via 8753D   or   H=
HP-IB
840     !  Main_port$      [REFL|TRANS]
850     !  Switched_port$  [0|1|2|...|12]
860     !  Addr            HP-IB addr of 8753D or 87050
depending upon H or P above
870
!-----
880     !  DESCRIPTION:
890     !
900     !      Eight bits control the HP 87050A:
d7|d6|d5|d4|d3|d2|d1|d0
910     !
920     !      d7 \  Test set address bits.  Two bits allow up to 4
test sets
930     !      d6 /  to be addressed with Centronics connector.  Test
set
940     !      addresses are set with rear panel switch.
950     !
960     !      d5    for future customization
970     !
980     !      d4    selects port1/port2 (Reflection or Transmission)
990     !      "0" selects port 1 as active.  "1" selects port
2.
1000    !
```

Example Programs

```
1010      !      d3 \
1020      !      d2 \ Four bits select which port of the HP 87050A is
1030      !      d1 / connected to the active network analyzer port.
1040      !      d0 /
1050      !
1060      !      Commands can be sent via Centronics (Parallel) port or
via HP-IB.
1070      !      Choice depends upon variable Controller$ (P/H)
1080      !
1090
!=====
1100 Set_switches:!
1110      !
1120      SELECT UPC$(TRIM$(Main_port$))
1130      CASE "REFL","REFLECTION"
1140          SELECT UPC$(TRIM$(Switched_port$))
1150          CASE "1","PORT 1"
1160              Switch_code$="00000000"
1170          CASE "2","PORT 2"
1180              Switch_code$="00000001"
1190          CASE "3","PORT 3"
1200              Switch_code$="00000010"
1210          CASE "4","PORT 4"
1220              Switch_code$="00000011"
1230          CASE "5","PORT 5"
1240              Switch_code$="00000100"
1250          CASE "6","PORT 6"
1260              Switch_code$="00000101"
1270          CASE "7","PORT 7"
1280              Switch_code$="00000110"
1290          CASE "8","PORT 8"
1300              Switch_code$="00000111"
1390      !
1400      !
1410          CASE ELSE
1420              DISP "Unrecognized Switched_port$ parameter;
""&Switched_port$&""
1430              STOP
1440          END SELECT
1450      !
1460      CASE "TRANS","TRANSMISSION"
```

Controlling the Test Set
and Making Measurements

Example Programs

```
1470     SELECT UPC$(TRIM$(Switched_port$))
1480     CASE "1","PORT 1"
1490         Switch_code$="00010000"
1500     CASE "2","PORT 2"
1510         Switch_code$="00010001"
1520     CASE "3","PORT 3"
1530         Switch_code$="00010010"
1540     CASE "4","PORT 4"
1550         Switch_code$="00010011"
1560     CASE "5","PORT 5"
1570         Switch_code$="00010100"
1580     CASE "6","PORT 6"
1590         Switch_code$="00010101"
1600     CASE "7","PORT 7"
1610         Switch_code$="00010110"
1620     CASE "8","PORT 8"
1630         Switch_code$="00010111"
1720 !
1730 !
1740     CASE ELSE
1750         DISP "Unrecognized Switched_port$ parameter;
1760         """"&Switched_port$&""""
1770         STOP
1780     END SELECT
1790     CASE ELSE
1800         DISP "Unrecognized Main_port$ parameter;
1810         """"&Main_port$&""""
1820         STOP
1830     END SELECT
1840     !
1850     Output_cmd$=VAL$(DVAL(Switch_code$,2))
1860     IF Controller$="H" THEN
1870         OUTPUT Addr;CHR$(VAL(Output_cmd$)); ! sent via HP-IB
1880     ELSE
1890         OUTPUT Addr;"PARALGPIO;" ! sent via
Centronics
1900         OUTPUT Addr;"PARAOUT"&Output_cmd$&";" ! port
1910     END IF
1920     WAIT .1
1930 SUBEND
1940
```

Controlling the Test Set
and Making Measurements
Example Programs

!*****

Controlling the Test Set
and Making Measurements

Example Programs

————— Front/Rear Panel

Front/Rear Panel

This chapter contains information on the ports and switches found on the front and rear panels of the test set. This chapter is divided into two sections: front panel and rear panel.

Front Panel

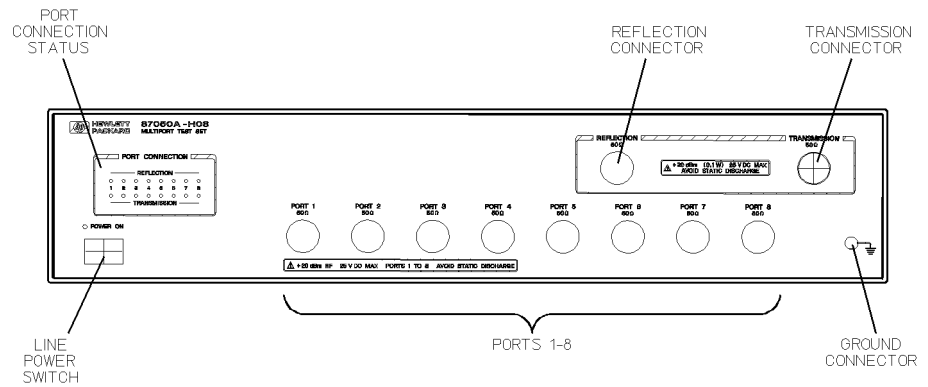

pt616a

Figure 4.1. Front Panel Features

Line Power Switch

The test set line POWER switch is located at the bottom left corner of the front panel. See Figure 4-1. The line POWER switch turns the power to the test set either on (**I**) or off (**O**).

The front panel LINE switch disconnects the mains circuits from the mains supply after the EMC filters and before others parts of the instrument.

Ports 1–8

Ports 1 through 8 are used to connect to the device under test.

CAUTION

Do not input more than +20 dBm or 25 Vdc to these ports or damage to the internal RF switches or the analyzer may occur.

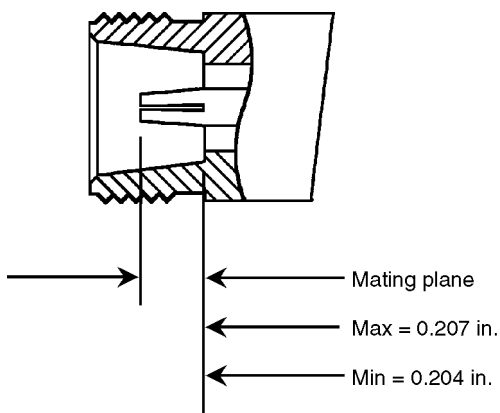

po644 b_c

Figure 4-2. Physical Description of Type-N Connector

The REFLECTION Connector

The REFLECTION connector is a female type-N 50 Ω connector that connects directly to the reflection or Port 1 (RF OUT) port of the network analyzer using the flexible cable (HP part number 87050-60024) that was shipped with your test set.

CAUTION

Check your analyzer's documentation for damage limits to the RF OUT port. Make sure that your test setup will not cause those limits to be exceeded.

The TRANSMISSION Connector

The TRANSMISSION connector is a female type-N 50 Ω connector that connects directly to the transmission or Port 2 (RF IN) port of the network analyzer using the flexible cable (HP part number 87050-60024) that was shipped with your test set.

CAUTION

Check your analyzer's documentation for damage limits to the RF IN port. Make sure that your test setup will not cause those limits to be exceeded.

The GROUND Connector

The GROUND connector provides a convenient front panel ground connection for a standard banana plug.

The PORT CONNECTION Status LEDs

The PORT CONNECTION status LEDs provide visual feedback of which port(s) are connected to the REFLECTION and TRANSMISSION ports of the test set. When the LED is not lit, the test port is internally terminated in 50 Ω .

All status LEDs are off when first powered on, when the Reflection or Transmission is selected the status LEDs shows which port is selected. If the Reflection and Transmission are both selected to a single port (ie. Transmission port 1 and Reflection port 1) the LEDs turn off. This is an indication of an illegal operation. The Reflection and Transmission commands cannot use the same port simultaneously or damage to the internal switch will occur. All switches are turned off during an illegal operation until the operator changes the illegal operation to a legal operation.

Rear Panel

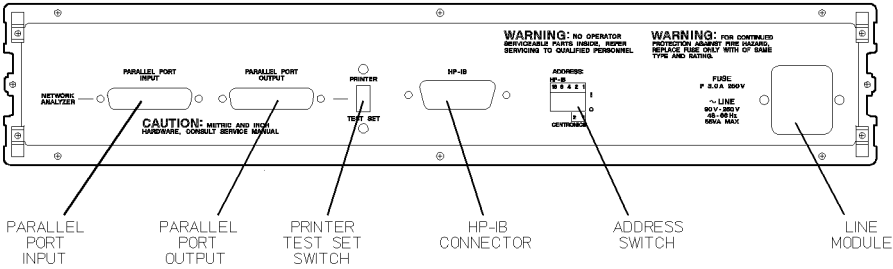

pr61b

Figure 4.3. Rear Panel Features

The PARALLEL PORT INPUT Connector

This input is connected to the network analyzer. The analyzer provides control signals that drive the switches inside the test set. In pass-through mode, it also accepts signals required to drive a printer.

The PARALLEL PORT OUTPUT Connector

The output from this connector can be signals to control another test set, or signals to control a printer, depending upon how the PRINTER/TEST SET switch is set.

The PRINTER/TEST SET Switch

This switch determines the function of the PARALLEL PORT OUTPUT connector. When switched to PRINTER, the PARALLEL PORT OUTPUT will pass-through printer driver signals. When switched to TEST SET, an additional test set can be controlled from the PARALLEL PORT OUTPUT connector.

HP-IB Connector

This connector allows the test set to be connected directly to a controller. See Figure 3-2.

Address Switch

The address switch sets the HP-IB and/or parallel address of the test set. See “Setting the Test Set Address Switch” in Chapter 2 for information.

Line Module

The line module contains the power cable receptacle and the line fuse.

Power Cables

The line power cable is supplied in one of several configurations, depending on the destination of the original shipment.









Each instrument is equipped with a three-wire power cable. When connected to an appropriate ac power receptacle, this cable grounds the instrument chassis. The type of power cable shipped with each instrument depends on the country of destination. See Figure 4-4, “Power Cable and Line (Mains) Plug Part Numbers”, for the part numbers of these power cables. Cables are available in different lengths. Check with your nearest Hewlett-Packard service center for descriptions and part numbers of cables other than those described in Figure 4-4.

WARNING

This is a Safety Class I product (provided with a protective earthing ground incorporated in the power cord). The mains plug shall only be inserted in a socket outlet provided with a protective earth contact. Any interruption of the protective conductor, inside or outside the instrument, is likely to make the instrument dangerous. Intentional interruption is prohibited.

Front/Rear Panel

Rear Panel

Plug Type ^a	HP Cable Part Number	Plug ^b Description	Length cm (in.)	Cable Color	For Use in Country
250V 	8120-1351	Straight BS 1363A	229 (90)	Mint Gray	Option 900 United Kingdom, Hong Kong, Cyprus, Nigeria, Singapore, Zimbabwe
	8120-1703	90°	229 (90)	Mint Gray	
250V 	8120-1369	Straight AS 3112	210 (79)	Gray	Option 901 Argentina, Australia, New Zealand, Mainland China
	8120-0696	90°	200 (78)	Gray	
125V 	8120-1378	Straight NEMA 5-15P	203 (80)	Jade Gray	Option 903 United States, Canada, Brazil, Colombia, Mexico, Philippines, Saudi Arabia, Taiwan
	8120-1521	90°	203 (80)	Jade Gray	
125V 	8120-4753	Straight NEMA 5-15P	229 (90)	Gray	Option 918 Japan
	8120-4754	90°	229 (90)	Gray	
250V 	8120-1689	Straight CEE 7/VII	200 (78)	Mint Gray	Option 902 Continental Europe, Central African Republic, United Arab Republic
	8120-1692	90°	200 (78)	Mint Gray	
230V 	8120-2104	Straight SEV Type 12	200 (78)	Gray	Option 906 Switzerland
	8120-2296	90°	200 (78)	Gray	
220V 	8120-2956	Straight SR 107-2-D	200 (78)	Gray	Option 912 Denmark
	8120-2957	90°	200 (78)	Gray	
250V 	8120-4211	Straight IEC 83-B1	200 (78)	Mint Gray	Option 917 South Africa, India
	8120-4600	90°	200 (78)	Mint Gray	
250V 	8120-5182	Straight SI 32	200 (78)	Jade Gray	Option 919 Israel
	8120-5181	90°	200 (78)	Jade Gray	

a. E = earth ground, L = line, and N = neutral.

b. Plug identifier numbers describe the plug only. The HP part number is for the complete cable assembly.

formt119

Figure 4-4. Power Cable and Line (Mains) Plug Part Numbers

The Line Fuse

The line fuse (F 3 A/250 V, HP part number 2110-0780), and a spare, reside within the line module. Figure 4-5 illustrates where the fuses are and how to access them.

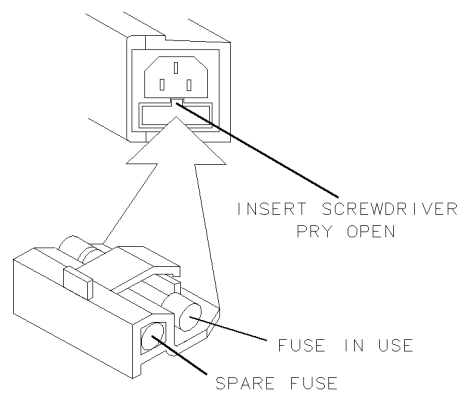

FORMAT48

Figure 4-5. Location of Line Fuses

Front/Rear Panel

Rear Panel

— Specifications

Specifications

Specifications and Characteristics

Table 5-1. 87050A Specifications

Parameter	Specification
Frequency Range	300 kHz to 6 GHz
Isolation ¹	>90 dB
Return Loss ²	
300 kHz to 1.3 GHz	>25 dB
1.3 GHz to 3.0 GHz	>18 dB
3.0 GHz to 6.0 GHz	>14 dB
Insertion Loss ³	
300 kHz to 1.3 GHz	<1.25 dB
1.3 GHz to 3.0 GHz	<1.5 dB
3.0 GHz to 6.0 GHz	<2.5 dB
Input Power Damage Level	> +20 dBm

1 Between any two non-connected signal paths

2 When externally terminated in 50 Ω

3 From any test set port to the reflection or transmission port

General Characteristics

Environmental Characteristics

General Conditions	ESD (electrostatic discharge): must be eliminated by use of static-safe work procedures and an anti-static bench mat (such as HP 92175T).
Operating Environment	Indoor use only Operating temperature: 0 ° to 55 °C Maximum relative humidity: 80 percent for temperatures up to 31 °C decreasing linearly to 50 percent relative humidity at 40 °C. Altitude: up to 15,000 feet (4,572 meters)
Non-Operating Storage Conditions	Temperature: -40 °C to +70 °C Humidity: 0 to 90 percent relative at +65 °C (non-condensing) Altitude: 0 to 15,240 meters (50,000 feet)
Weight	Net: Approximately 9 kg Shipping: Approximately 22 kg
Cabinet Dimensions	These dimensions exclude front and rear panel protrusions. 89 mm H × 425 mm W × 500 mm D (3.51 in × 16.75 in × 19.7 in)

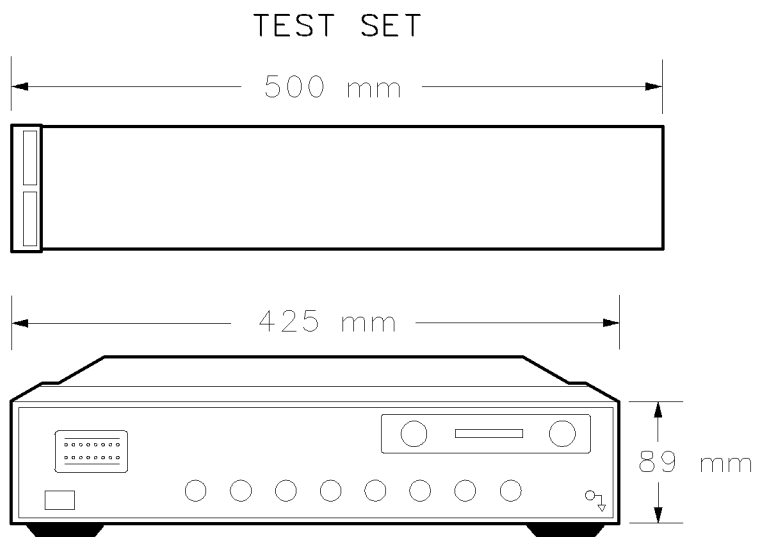

pr610b

Physical Dimensions

Hewlett-Packard Sales and Service Offices

If you should need technical assistance, contact the nearest Hewlett-Packard sales or service office. See Table 5-2 on the next page.

HP 87050A Option H08 Options

UK6

Option UK6 provides a commercial calibration certificate including actual test data. Data includes test results of 23 tests including reflection, transmission, and isolation.

Rack Ear Mounts

Option 908 (HP p/n 5062-3974) provides rack mounts that make it quick and easy to install or remove the test set from a main frame.

For further information on these options please contact the nearest Hewlett-Packard sales or service office. See Table 5-2 on the next page.

Hewlett-Packard Sales and Service Offices

Table 5-2. Hewlett-Packard Sales and Service Offices

US FIELD OPERATIONS			
<p>Headquarters Hewlett-Packard Co. 19320 Pruneridge Ave. Cupertino, CA 95014 (800) 752-0900</p>	<p>California, Northern Hewlett-Packard Co. 301 E. Evelyn Mountain View, CA 94041 (415) 694-2000</p>	<p>California, Southern Hewlett-Packard Co. 1421 South Manhattan Ave. Fullerton, CA 92631 (714) 999-6700</p>	<p>Colorado Hewlett-Packard Co. 24 Inverness Place, East Englewood, CO 80112 (303) 649-5512</p>
<p>Atlanta Annex Hewlett-Packard Co. 2124 Barrett Park Drive Kennesaw, GA 30144 (404) 648-0000</p>	<p>Illinois Hewlett-Packard Co. 5201 Tollview Drive Rolling Meadows, IL 60008 (708) 255-9800</p>	<p>New Jersey Hewlett-Packard Co. 150 Green Pond Rd. Rockaway, NJ 07866 (201) 586-5400</p>	<p>Texas Hewlett-Packard Co. 930 E. Campbell Rd. Richardson, TX 75081 (214) 231-6101</p>
EUROPEAN FIELD OPERATIONS			
<p>Headquarters Hewlett-Packard S.A. 150, Route du Nant-d'Avril 1217 Meyrin 2/Geneva Switzerland (41 22) 780.8111</p>	<p>France Hewlett-Packard France 1 Avenue Du Canada Zone D'Activite De Courtaboeuf F-91947 Les Ulis Cedex France (33 1) 69 82 60 60</p>	<p>Germany Hewlett-Packard GmbH Hewlett-Packard Strasse 61352 Bad Homburg v.d.H Germany (49 6172) 16-0</p>	<p>Great Britain Hewlett-Packard Ltd. Eskdale Road, Winnersh Triangle Wokingham, Berkshire RG41 5DZ England (44 734) 696622</p>
INTERCON FIELD OPERATIONS			
<p>Headquarters Hewlett-Packard Company 3495 Deer Creek Road Palo Alto, California, USA 94304-1316 (415) 857-5027</p>	<p>Australia Hewlett-Packard Australia Ltd. 31-41 Joseph Street Blackburn, Victoria 3130 (61 3) 895-2895</p>	<p>Canada Hewlett-Packard (Canada) Ltd. 17500 South Service Road Trans- Canada Highway Kirkland, Quebec H9J 2X8 Canada (514) 697-4232</p>	<p>China China Hewlett-Packard Company 38 Bei San Huan X1 Road Shuang Yu Shu Hai Dian District Beijing, China (86 1) 256-6888</p>
<p>Japan Hewlett-Packard Japan, Ltd. 1-27-15 Yabe, Sagami-hara Kanagawa 229, Japan (81 427) 59-1311</p>	<p>Singapore Hewlett-Packard Singapore (Pte.) Ltd. 150 Beach Road #29-00 Gateway West Singapore 0718 (65) 291-9088</p>	<p>Taiwan Hewlett-Packard Taiwan 8th Floor, H-P Building 337 Fu Hsing North Road Taipei, Taiwan (886 2) 712-0404</p>	

Specifications

Hewlett-Packard Sales and Service Offices

Service

Service

This chapter contains information on how to verify the performance of your test set, how to troubleshoot it if necessary, and theory of operation and a block diagram.

Please read all applicable safety warnings and cautions in Chapter 7 before servicing the test set.

Performance Tests

Performance testing consists of measuring insertion loss, return loss, and isolation between all ports. Full performance testing instructions are not provided in this manual. However a brief, general description of each test is provided. For the most accurate measurements, the use of an HP 8753D 50 Ω network analyzer is recommended and its use is assumed in these notes. Familiarity with RF/microwave measurements is also assumed. The use of adapters may be required and their effects should be accounted for.

Performance tests will require the following equipment:

- HP 8753D Option 006
- HP 11857D test port extension cables
- HP 85032B cal kit
- HP 909A or 00909-60002 50 Ω load

Make a photocopy of the performance test record card (later in this chapter) to record the results of the performance tests. There are no adjustments required for the HP 87050A H08 test set.

Insertion Loss

1. Perform a full two-port calibration from 300 kHz to 6.0 GHz at the ends of two cables attached to the two test ports of the HP 8753D. Make sure the calibration is active.
2. Connect the cable that is attached to PORT 1 of the 8753D to the REFLECTION port of the HP 87050A.
3. Connect the cable from PORT 2 of the analyzer to PORT 1 of the HP 87050A. Using the "CONTROL" program provided (see "Example Programs" in Chapter 3), select reflection port 1. e.g. "1,0" (the selected transmission port does not matter). Verify the insertion loss for each of the frequency bands listed in Table 6-1.
4. Repeat step 3 for each of the remaining test ports 2 through 8.

Performance Tests

- Repeat steps 2 through 4, but connect the cable in step 2 to the TRANSMISSION port of the HP 87050A. In step 3, select only the transmission port instead of the reflection port. e.g. "0,1".

Table 6-1. Insertion Loss Specifications

Frequency Range	Specification (dB)
300 kHz to 1.3 GHz	<1.25 dB
1.3 GHz to 3 GHz	<1.5 dB
3 GHz to 6 GHz	<2.5 dB

Return Loss

This test will check both the internal termination load of each port, as well as the through match when the appropriate input port is terminated with a load.

1. Perform a one-port reflection calibration at the end of a 50 Ω cable over the frequency range of 300 kHz to 6.0 GHz on the analyzer. Verify the calibration is active and that the unterminated cable displays a return loss of 0 ± 0.2 dB.
2. Connect the cable (already connected to the REFLECTION measurement port of the analyzer) to PORT 1 of the HP 87050A. Connect a high-quality 50 Ω load to the REFLECTION port of the HP 87050A. Measure the return loss of PORT 1 by selecting port 1 via the “CONTROL” program. e.g. “1,0” and viewing the display on the analyzer.
3. Repeat this measurement again, but this time select another port. LED of the port being measured should be off. This will test the internal load for the port under test.
4. Move the cable to PORT 2 and repeat steps 2 and 3, selecting PORT 2 as the “CONTROL” program entry in step 2. Repeat steps 2 and 3 for the remaining ports.

The return loss specification for any input match when properly terminated is described in Table 6-2. Calibration errors and limitations will typically result in 0.5 to 1 dB of uncertainty.

Table 6-2. Return Loss Specifications

Frequency Range	Specification (dB)
300 kHz to 1.3 Ghz	>25 dB
1.3 Ghz to 3 Ghz	>18 dB
3 Ghz to 6 Ghz	>14 dB

Isolation

Isolation need only be measured on adjacent ports. Two 50 Ω loads are required for this test.

1. Perform a full two-port calibration (from 300 kHz to 6.0 GHz) at the ends of two cables attached to the two ports of the HP 8753D. Make sure the calibration is active.
2. Connect a 50 Ω load to both the REFLECTION and TRANSMISSION ports of the HP 87050A.
3. Connect the two cables that are attached to the network analyzer, to ports 1 and 2 of the HP 87050A. The exact order doesn't matter.
4. Using the "CONTROL" program provided, select reflection port 1 and transmission port 2. e.g. "1,2" (you could also use "2,1"). Set the HP 8753D to measure transmission. Verify > 90 dB of insertion loss.
5. Repeat steps 3 and 4 for the next two adjacent ports; 2 and 3. Make sure the appropriate "CONTROL" inputs are selected. Repeat again for ports 3 and 4, then 4 and 5, and so on, ending with ports 7 and 8.

Switch Repeatability

Switch repeatability need only be measured on adjacent ports. One additional 50 Ω type-N (F) RF cable is required for this test.

1. The “Isolation” performance test must be performed with valid results before performing this switch repeatability test.
2. Connect the two cables that are attached to the network analyzer, to the REFLECTION and TRANSMISSION ports on the HP 87050A.
3. Connect the RF cable between ports 1 and 2 on the HP 87050A.
4. Using the “CONTROL” program provided, select reflection port 1 and transmission port 2. e.g. “1,2”.
5. Set the HP 8753D to measure transmission. Normalize trace `DATA -> MEMORY DATA/MEM` and change the scale to 0.1 dB per division.
6. Switch ports to select reflection port 2 and transmission port 1. e.g. “2,1”. Verify < 0.1 dB of deviation.
7. Repeat steps 4 through 6 for the next two ports; 2 and 3. Make sure the appropriate “CONTROL” inputs are selected. Repeat again for ports 3 and 4, then 4 and 5, and so on, ending with ports 7 and 8.

Service
Performance Tests

Performance Test Record

HP 87050A H08 Test Record (1 of 8)

Test Facility _____ _____ _____	Report Number _____ Date _____ Date of Last System Calibration _____ _____		
Tested by _____	Customer _____		
Model _____	Serial Number _____		
Ambient temperature _____ °C	Relative Humidity _____ %		
Test Equipment Used	Model Number	Trace Number	Cal Due Date
_____	_____	_____	_____
_____	_____	_____	_____
_____	_____	_____	_____
_____	_____	_____	_____
_____	_____	_____	_____
Special Notes: _____ _____ _____ _____ _____			

HP 87050A H08 Test Record (2 of 8)

Test Description	Port	Specification	Measured Results	Measurement Uncertainty
Insertion Loss to Reflection Port 300 kHz to 1.3 GHz	Port 1	< 1.25 dB	_____	±0.1 dB
	Port 2	< 1.25 dB	_____	±0.1 dB
	Port 3	< 1.25 dB	_____	±0.1 dB
	Port 4	< 1.25 dB	_____	±0.1 dB
	Port 5	< 1.25 dB	_____	±0.1 dB
	Port 6	< 1.25 dB	_____	±0.1 dB
	Port 7	< 1.25 dB	_____	±0.1 dB
	Port 8	< 1.25 dB	_____	±0.1 dB
Insertion Loss to Reflection Port 1.3 GHz to 3.0 GHz	Port 1	< 1.5 dB	_____	±0.4 dB
	Port 2	< 1.5 dB	_____	±0.4 dB
	Port 3	< 1.5 dB	_____	±0.4 dB
	Port 4	< 1.5 dB	_____	±0.4 dB
	Port 5	< 1.5 dB	_____	±0.4 dB
	Port 6	< 1.5 dB	_____	±0.4 dB
	Port 7	< 1.5 dB	_____	±0.4 dB
	Port 8	< 1.5 dB	_____	±0.4 dB

Service
Performance Tests

HP 87050A H08 Test Record (3 of 8)

Test Description	Port	Specification	Measured Results	Measurement Uncertainty
Insertion Loss to Reflection Port 3.0 GHz to 6.0 GHz	Port 1	<2.5 dB	_____	±0.2 dB
	Port 2	<2.5 dB	_____	±0.2 dB
	Port 3	<2.5 dB	_____	±0.2 dB
	Port 4	<2.5 dB	_____	±0.2 dB
	Port 5	<2.5 dB	_____	±0.2 dB
	Port 6	<2.5 dB	_____	±0.2 dB
	Port 7	<2.5 dB	_____	±0.2 dB
	Port 8	<2.5 dB	_____	±0.2 dB

HP 87050A H08 Test Record (4 of 8)

Test Description	Port	Specification	Measured Results	Measurement Uncertainty
Insertion Loss to Transmission Port 300 kHz to 1.3 GHz	Port 1	<1.25 dB	_____	±0.1 dB
	Port 2	<1.25 dB	_____	±0.1 dB
	Port 3	<1.25 dB	_____	±0.1 dB
	Port 4	<1.25 dB	_____	±0.1 dB
	Port 5	<1.25 dB	_____	±0.1 dB
	Port 6	<1.25 dB	_____	±0.1 dB
	Port 7	<1.25 dB	_____	±0.1 dB
	Port 8	<1.25 dB	_____	±0.1 dB
Insertion Loss to Transmission Port 1.3 GHz to 3.0 GHz	Port 1	<1.5 dB	_____	±0.4 dB
	Port 2	<1.5 dB	_____	±0.4 dB
	Port 3	<1.5 dB	_____	±0.4 dB
	Port 4	<1.5 dB	_____	±0.4 dB
	Port 5	<1.5 dB	_____	±0.4 dB
	Port 6	<1.5 dB	_____	±0.4 dB
	Port 7	<1.5 dB	_____	±0.4 dB
	Port 8	<1.5 dB	_____	±0.4 dB

Service
Performance Tests

HP 87050A H08 Test Record (5 of 8)

Test Description	Port	Specification	Measured Results	Measurement Uncertainty
Insertion Loss to Transmission Port 3.0 GHz to 6.0 GHz	Port 1	<2.5 dB	_____	±0.2 dB
	Port 2	<2.5 dB	_____	±0.2 dB
	Port 3	<2.5 dB	_____	±0.2 dB
	Port 4	<2.5 dB	_____	±0.2 dB
	Port 5	<2.5 dB	_____	±0.2 dB
	Port 6	<2.5 dB	_____	±0.2 dB
	Port 7	<2.5 dB	_____	±0.2 dB
	Port 8	<2.5 dB	_____	±0.2 dB

HP 87050A H08 Test Record (6 of 8)

Test Description	Port	Specification	Measured Results	Measurement Uncertainty
Return Loss 300 kHz to 1.3 GHz	Port 1	> 25 dB	_____	±0.6 dB
	Port 2	> 25 dB	_____	±0.6 dB
	Port 3	> 25 dB	_____	±0.6 dB
	Port 4	> 25 dB	_____	±0.6 dB
	Port 5	> 25 dB	_____	±0.6 dB
	Port 6	> 25 dB	_____	±0.6 dB
	Port 7	> 25 dB	_____	±0.6 dB
	Port 8	> 25 dB	_____	±0.6 dB
Return Loss 1.3 GHz to 3.0 GHz	Port 1	> 18 dB	_____	±0.4 dB
	Port 2	> 18 dB	_____	±0.4 dB
	Port 3	> 18 dB	_____	±0.4 dB
	Port 4	> 18 dB	_____	±0.4 dB
	Port 5	> 18 dB	_____	±0.4 dB
	Port 6	> 18 dB	_____	±0.4 dB
	Port 7	> 18 dB	_____	±0.4 dB
	Port 8	> 18 dB	_____	±0.4 dB

Service
Performance Tests

HP 87050A H08 Test Record (7 of 8)

Test Description	Port	Specification	Measured Results	Measurement Uncertainty
Return Loss 3.0 GHz to 6.0 GHz	Port 1	> 14 dB	_____	±0.6 dB
	Port 2	> 14 dB	_____	±0.6 dB
	Port 3	> 14 dB	_____	±0.6 dB
	Port 4	> 14 dB	_____	±0.6 dB
	Port 5	> 14 dB	_____	±0.6 dB
	Port 6	> 14 dB	_____	±0.6 dB
	Port 7	> 14 dB	_____	±0.6 dB
	Port 8	> 14 dB	_____	±0.6 dB

HP 87050A H08 Test Record (8 of 8)

Test Description	Port	Specification	Measured Results	Measurement Uncertainty
Isolation	Port 1 to 2	> 90 dB	_____	±5 dB
	Port 2 to 3	> 90 dB	_____	±5 dB
	Port 3 to 4	> 90 dB	_____	±5 dB
	Port 4 to 5	> 90 dB	_____	±5 dB
	Port 5 to 6	> 90 dB	_____	±5 dB
	Port 6 to 7	> 90 dB	_____	±5 dB
	Port 7 to 8	> 90 dB	_____	±5 dB
Switch Repeatability	Port 1 to 2	< 0.1 dB	_____	±0.4 dB
	Port 2 to 3	< 0.1 dB	_____	±0.4 dB
	Port 3 to 4	< 0.1 dB	_____	±0.4 dB
	Port 4 to 5	< 0.1 dB	_____	±0.4 dB
	Port 5 to 6	< 0.1 dB	_____	±0.4 dB
	Port 6 to 7	< 0.1 dB	_____	±0.4 dB
	Port 7 to 8	< 0.1 dB	_____	±0.4 dB

Adjustments

There are no adjustments for the test set.

Troubleshooting and Block Diagram

This section contains information on troubleshooting the test set to assembly level only. Following these procedures should enable you to determine whether the power supply, front panel, or main switch board need replacing. A block diagram is included at the end of this section as an aid in troubleshooting.

Theory of operation information can be found in the next section of this manual.

General Troubleshooting Notes

WARNING

Always turn the instrument power off before removing or installing an assembly.

CAUTION

If you need to disassemble the instrument, be sure to work at an antistatic workstation and use a grounded wrist strap to prevent damage from electrostatic discharge (ESD).

Troubleshooting Power Supply Problems

Turn the instrument power on. Check the condition of the LED on the front panel:

- If it is on, there is still a possibility that the power supply is not supplying the necessary +24V, +12V, and +5V to the controller motherboard.
- If the LED is off, check the main fuse located in the power supply filter at the rear of the instrument.

Troubleshooting and Block Diagram

- If the LED is still off, check the cable between the switch driver daughterboard and the front panel board.
- If the LED is still off, check the cable between the controller motherboard and the switch driver daughterboard.
- Finally, disconnect the DC power cable from the power supply to the controller motherboard board and measure the voltages. They should be +24V, +12V, and +5V. If not, replace the power supply.

Troubleshooting the Front Panel Board

Turn the instrument power on and check the following:

- Check the condition of each of the switching paths by issuing commands to switch each of the paths to either the transmission or reflection path. Ensure that the correct LED is turned on.
- If an LED remains on when it shouldn't, the problem can lie with either the front panel board, the controller board, or the switch driver board. Measure the RF path to determine where the problem is.
- Ensure that the front panel washers—between the board and front panel assembly—are present. Missing washers can cause erratic LED behavior.
- If an LED does not light, check to see if the RF path has indeed been switched. If the problem lies with the front panel board, replace it.

Troubleshooting the Controller and Switch Driver Boards

Turn the instrument power on. Check the condition of each of the switching paths by issuing commands to switch each of the paths to either the transmission or reflection path. Check each of the RF paths for connection. If

an RF path is not connected to the necessary port or terminated in 50 ohms, replace the controller and switch driver board.

Block Diagrams

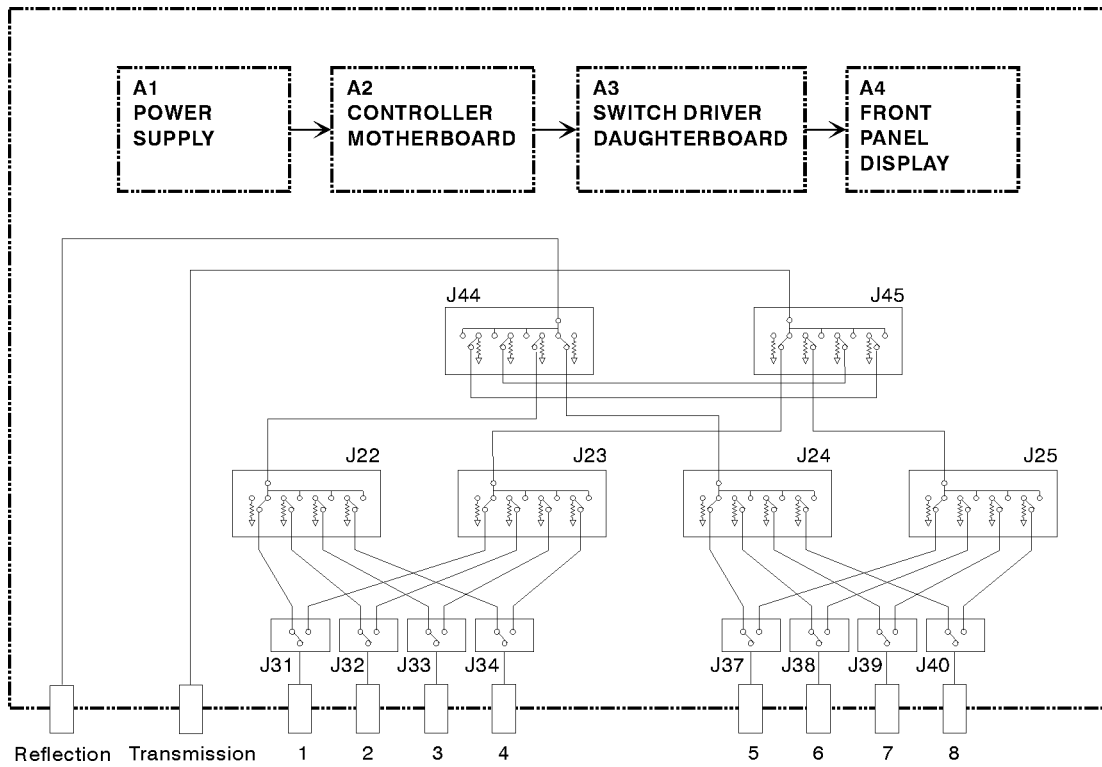

pt617a

Figure 6-1. HP 87050A-H08 Block Diagram for Serial Numbers US 36130100–US 36130121

Troubleshooting and Block Diagram

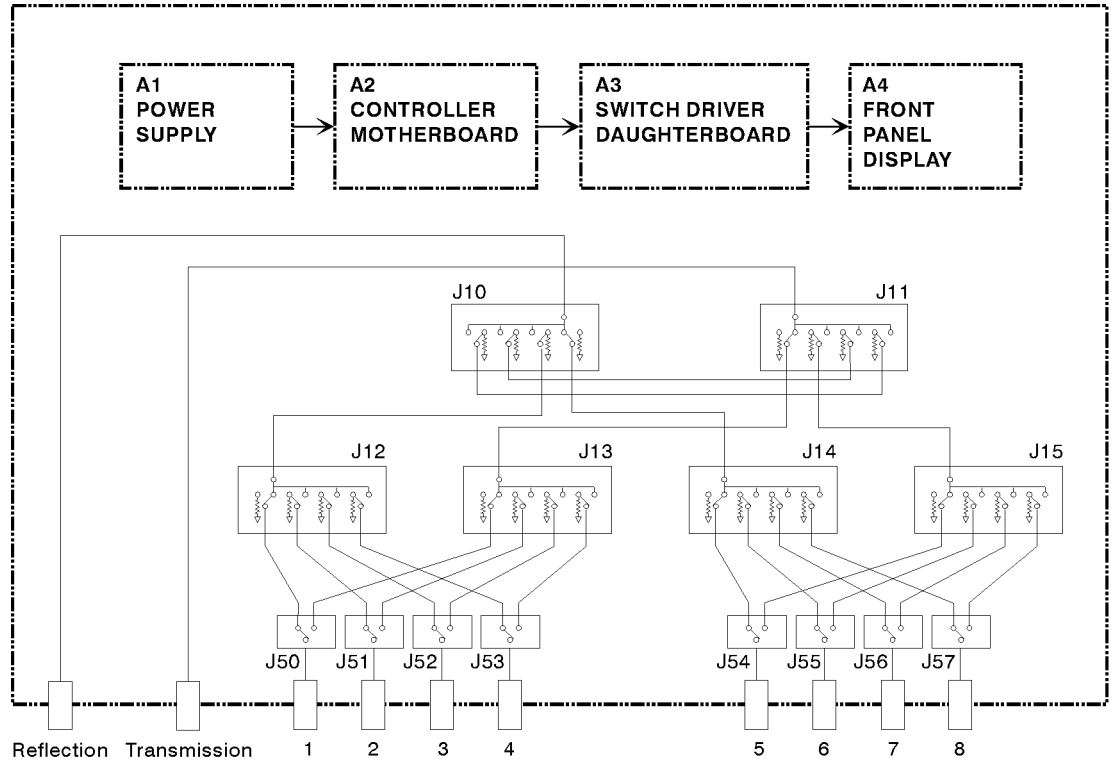

pt618a

Figure 6-2. HP 87050A-H08 Block Diagram for Serial Numbers US 36130122 and above

Theory of Operation

The theory of operation begins with a general description of the HP 87050A H08 multiport test set. This is followed by more detailed operating theory. The operation of each group is described briefly, to the assembly level only. Detailed component-level circuit theory is not provided.

System Theory

The test set consists of four main components: a power supply, front panel display, controller motherboard, and switch driver daughterboard. The purpose of the power supply is to supply power to the front panel display, and the mother and daughterboards. The front panel display serves to indicate the switching paths to the user. Finally, the controller motherboard and switch driver daughterboards control the actual switching between the different ports.

A1 Power Supply Theory

The switching power supply provides regulated DC voltages to power all assemblies in the test set. A DC cable provides power to the controller motherboard. Another DC cable provides power from the controller motherboard to the switch driver daughterboard. A connector from the switch driver daughterboard to the front panel display provides DC power and control signals to the front panel. The power supply provides the following supplies: +5V, +24V, +12V.

The power LED on the front panel indicates that the instrument is on and that the power supply is providing power.

A2 Front Panel Display Theory

The front panel display consists of eight LEDs. These eight LEDs are divided into two groups: reflection and transmission. The first four LEDs in each group indicate which of the four ports are connected to the reflection port and which of the four LEDs are connected to the transmission port. Control signals and DC power are provided via a cable connected to the switch driver daughterboard.

A power LED on the front panel indicates power is being applied to the front panel through the main switch board from the power supply.

A3 Controller (Motherboard) and Switch Driver (Daughterboard) Board Theory

Refer to Figure 6-1 for the following discussion.

The motherboard and daughterboard provides the Bias for the switching paths for the various ports to the transmission or reflection port. The front panel display contains LEDs that indicate the switched ports. A particular port (1 through 8) can be in one of three states. The three states are:

- switched to the transmission port
- switched to the reflection port
- terminated in 50 ohms

When a port is not connected to either the transmission port or reflection port, it is automatically terminated in 50 ohms. Only one port can be connected to the transmission port and only one port can be connected to the reflection port at any given time.

The test set consists of eight 1x3 switches, and six 1x4 switches. The 1x3 switches divide each of the input ports (1 through 8) into two separate paths. One of these paths is terminated into 50 ohms and the other two are separated into either the transmission path or reflection path.

Service

Theory of Operation

The eight 1x6 switches combine each of the four 1x4 switches into four banks. These four banks are divided into two for the transmission port and two for the reflection port. Finally, the two 1x4 switches recombine the four banks into either the transmission port or reflection port.

All switches are mechanical which are biased according to the necessary switching path. A user interface through the HP-IB and parallel ports convert the necessary input signals from the user to the necessary control signals to control the switching paths.

Replaceable Parts and Post-Repair Procedures

The following table contains the list of replaceable parts for the HP 87050A H08 test set. If any of these parts or assemblies are replaced, refer to the table to determine if you must perform performance tests to verify conformance to specifications.

Replaceable Parts and Post-Repair Procedures**Table 6-3. Replaceable Parts and Post-Repair Procedures**

Replacement Part	HP Part Number	Post-Repair Procedures
RF Conn 50 Ω	5061-5386	All performance tests
Power supply board	0950-2252	All performance tests
Front panel	87050-00001	All performance tests
Main deck	87050-00004	All performance tests
Switch bracket	87050-00006	None
Switch bracket	87050-00007	None
Panel-fr sub	87075-00001	All performance tests
Rear panel	87075-00003	
Fan bracket	87075-00005	
Switch cable s22-s25	87050-60055	
Switch cable s31-34/37-40	87050-60053	
Switch ptr sts set	08711-60129	
Cable dis intcon	87075-60001	
Cable dc power	87075-60021	
Fan assembly	87050-60027	
Cable logic board power	87050-60022	
Cable logic board intcon	87050-60023	
RF board	87050-60049	
Logic board	87050-60051	
Front panel display board	87075-60003	
Cable ac line	87130-60007	
Switch assembly	33314b 024	
Switch assembly 1p4t	87104-60003	
Type-N connector assembly	5061-5386	

Replaceable Parts and Post-Repair Procedures**Table 6-3. Replaceable Parts and Post-Repair Procedures (continued)**

Replacement Part	HP Part Number	Post-Repair Procedures
Cable J3x to front panel	87050-20016	
Cable J44-1 to J22c	87050-20017	
Cable J44-2 to J24c	87050-20018	
Cable J45-1 to J23c	87050-20019	
Cable J45-2 to J25c	87050-60020	
Cable J22-1 to J31-1	87050-20021	
Cable J22-2 to J32-1	87050-20022	
Cable J22-3 to J33-1	87050-20023	
Cable J22-4 to J34-1	87050-20024	
Cable J23-1 to J31-2	87050-20025	
Cable J23-2 to J32-2	87050-20026	
Cable J23-3 to J33-2	87050-20027	
Cable J23-4 to J34-2	87050-20028	
Cable J24-1 to J37-1	87050-20029	
Cable J24-2 to J38-1	87050-20030	
Cable J24-3 to J39-1	87050-20031	
Cable J24-4 to J40-1	87050-20032	
Cable J25-1 to J37-2	87050-20033	
Cable J25-2 to J38-2	87050-20034	
Cable J25-3 to J39-2	87050-20035	
Cable J25-4 to J40-2	87050-20036	
Cable J45-c to trns pt	87050-20037	
Cable j44-c to refl pt	87050-20038	
APC-7 to f type-N adapter	85091-60001	

Connector Replacement

It is generally not possible to replace the front panel connectors in the field, since a special press is required. A possible alternative to repairing a damaged connector would be to just replace the center pin components. The three required components are:

Component	HP Part Number
RF CONN 50 OHM	1250-1577
CTR-CNDCT 50 OHM	5063-0078

These two components should be connected together using a liquid thread-locking adhesive such as HP part number 0470-1590. Re-use any shims and spacers from the connector being replaced. For best results, use a connector gauge to verify pin depth. See Figure 4-2 for proper pin-depth. Add or subtract spacers as required. Spacers and shims are also available from Hewlett-Packard.

**———— Safety and Regulatory
Information**

Safety and Regulatory Information

This chapter contains required safety and regulatory information that is not included elsewhere in the manual.

Safety Information

Much of the required safety information is distributed throughout this manual in appropriate places. This section contains all required safety information that is not included elsewhere in this manual.

Warnings

Warning Definition

Warning denotes a hazard. It calls attention to a procedure which, if not correctly performed or adhered to, could result in injury or loss of life. Do not proceed beyond a warning note until the indicated conditions are fully understood and met.

Warnings applicable to this instrument are:

WARNING

No operator serviceable parts inside. Refer servicing to qualified personnel. To prevent electrical shock, do not remove covers.

WARNING

If this instrument is not used as specified, the protection provided by the equipment could be impaired. This instrument must be used in a normal condition (in which all means for protection are intact) only.

WARNING

For continued protection against fire hazard replace line fuse only with same type and rating (F 3 A/250 V, HP part number 2110-0780). The use of other fuses or material is prohibited.

WARNING

This is a Safety Class I product (provided with a protective earthing ground incorporated in the power cord). The mains plug shall only be inserted in a socket outlet provided with a protective earth contact. Any interruption of the protective conductor, inside or outside the instrument, is likely to make the instrument dangerous. Intentional interruption is prohibited.

Safety and Regulatory Information

Safety Information

WARNING

The power cord is connected to internal capacitors that may remain live for 5 seconds after disconnecting the plug from its power supply.

WARNING

These servicing instructions are for use by qualified personnel only. To avoid electrical shock, do not perform any servicing unless you are qualified to do so.

WARNING

The opening of covers or removal of parts is likely to expose dangerous voltages. Disconnect the instrument from all voltage sources while it is being opened.

Cautions

Caution Definition

Caution denotes a hazard. It calls attention to a procedure that, if not correctly performed or adhered to, would result in damage to or destruction of the instrument. Do not proceed beyond a caution sign until the indicated conditions are fully understood and met.

Cautions applicable to this instrument are:

CAUTION

Always use the three-prong ac power cord supplied with this instrument. Failure to ensure adequate earth grounding by not using this cord may cause instrument damage.

CAUTION

This instrument has autoranging line voltage input; be sure the supply voltage is within the specified range.

CAUTION

This product is designed for use in Installation Category II and Pollution Degree 2 per IEC 1010 and 664 respectively.

CAUTION

Ventilation Requirements: When installing the instrument in a cabinet, the convection into and out of the instrument must not be restricted. The ambient temperature (outside the cabinet) must be less than the maximum operating temperature of the instrument by 4 °C for every 100 watts dissipated in the cabinet. If the total power dissipated in the cabinet is greater than 800 watts, then forced convection must be used.

Safety Information

Statement of Compliance

This instrument has been designed and tested in accordance with IEC Publication 1010, Safety Requirements for Electronic Measuring Apparatus, and has been supplied in a safe condition. The instruction documentation contains information and warnings which must be followed by the user to ensure safe operation and to maintain the instrument in a safe condition.

Cleaning Instructions

Clean the cabinet using a damp cloth only.

Shipping Instructions

Always transport or ship the instrument using the original packaging or comparable.

Instrument Markings



The instruction manual symbol. The product is marked with this symbol when it is necessary for the user to refer to the instructions in the manual.



The CE mark shows compliance with European Community. (If accompanied by a year, it is the year when the design was proven.)



The CSA mark is the Canadian Standards Association safety mark.



This symbol is used to mark the ON position of the power line switch.



This symbol is used to mark the OFF position of the power line switch.



This symbol indicates that the input power required is ac.

Regulatory Information

Notice for Germany: Noise Declaration

LpA < 70 dB
am Arbeitsplatz (operator position)
normaler Betrieb (normal position)
nach DIN 45635 T. 19 (per ISO 7779)

Declaration of Conformity

Safety and Regulatory Information
Regulatory Information

DECLARATION OF CONFORMITY

according to ISO/IEC Guide 22 and EN 45014

Manufacturer's Name: Hewlett-Packard Co.

Manufacturer's Address: Microwave Instruments Division
1400 Fountaingrove Parkway
Santa Rosa, CA 95403-1799
USA

declares that the product

Product Name: Multiport Test Set

Model Number: HP 87075B

Product Options: This declaration covers all options of the
above product.

conforms to the following Product specifications:

Safety: IEC 1010-1:1990+A1 / EN 61010-1:1993
CAN/CSA-C22.2 No. 1010.1-92

EMC: CISPR 11:1990/EN 55011:1991 Group 1, Class A
IEC 801-2:1984/EN 50082-1:1992 4 kV CD, 8 kV AD
IEC 801-3:1984/EN 50082-1:1992 3 V/m, 27-500 MHz
IEC 801-4:1988/EN 50082-1:1992 0.5 kV Sig. Lines, 1 kV Power Lines

IEC 555-2:1982 + A1:1985/EN 60555-2:1987
IEC 555-3:1982 + A1:1990/EN 60555-3:1987 + A1:1991

Supplementary Information:

The product herewith complies with the requirements of the Low Voltage Directive
73/23/EEC and the EMC Directive 89/336/EEC.

Santa Rosa, California, USA 30 Nov. 1995

Dixon Browder/Quality Manager

European Contact: Your local Hewlett-Packard Sales and Service Office or Hewlett-Packard GmbH, Department HQ-TRE,
Herrenberger Strasse 130, D-71034 Böblingen, Germany (FAX +49-7031-14-3143)



Index

Index

- A** altitude conditions, 5-4
atmospheric conditions, 5-4

- B** bits, control, 3-3
block diagrams, 6-20

- C** cabinet dimensions, 5-4
calibration, 3-9
caution definition, 7-5
CE mark definition, 7-7
Centronics address, 2-4
certificates, 5-6
checking the shipment, 1-3
cleaning instructions, 7-6
commands, 3-4
conditions for environment, 5-4
confidence check, 2-5
connection to analyzer, 2-3
connector
 - reflection, 4-5
 - transmission, 4-5connector damage, 6-28
connector/HP-IB, 4-8
connector Replacement, 6-28
connector replacement parts, 6-28
contents of shipment, 1-3
control bits, 3-3
controlling the test set, 3-2
CONTROL program, 3-15
CSA mark definition, 7-7
CYCLE program, 3-15

- D** declaration of conformity, 7-9
dimensions of analyzer, 5-4

- E** electrical requirements, 1-4
 - electrostatic
 - discharge, 1-7
 - precautions, 1-7
 - environmental characteristics, 5-4
 - environmental requirements, 1-4
 - ESD precautions, 1-7
 - example programs, 3-15

- F** front panel features, 4-2
 - front panel illustration, 4-3
 - fuse
 - line, 4-11
 - part number, 4-11
 - fuse, line, 7-3

- G** gain measurement, 3-12

- H** HP-IB address switch, 2-4
 - HP-IB connector, 4-8
 - humidity conditions, 5-4

- I** insertion loss measurement, 3-12
 - insertion loss performance test, 6-3
 - installation, 1-2
 - installation category, 1-4
 -  , 7-7
 - instruction manual symbol
 - defined, 7-7
 - instrument markings and symbols, 7-7
 - isolation performance test, 6-6

- L** line fuse
 - location, 4-11
 - ratings, 7-3
- line fuse part number, 7-3
- line module, 4-9
- line power requirements, 1-4
- line switch, 4-4
- line voltage requirements, 1-4

- M** measuring reflection, 3-14
measuring transmission, 3-12

- N** non-operating storage conditions, 5-4

- O** operating conditions, 5-4
operator's check, 2-5
option, 5-6

- P** parallel address, 2-4
parallel port input connector, 4-8
parallel port output connector, 4-8
part number, line fuse, 7-3
part numbers
 - static-safe equipment, 1-7parts, connector, 6-28
parts supplied with shipment, 1-3
performance test record, 6-8
performance tests, 6-3
physical dimensions, 5-4
pollution degree rating, 1-4
port connection LEDs, 4-6
ports 1—8, 4-4
power cable configurations, 4-9
power cable receptacle, 4-9
power cables, 4-9
power requirements, 1-4
power switch, 4-4
precautions
 - electrostatic, 1-7printer/test set switch, 4-8
programs, example, 3-15

- R** rack ear mount, 5-6
reflection connector, 4-5
reflection measurement, 3-14
requirements
 - electrical and environmental, 1-4return loss performance test, 6-5

- S** safety information, 7-3
- safety warnings, 7-3
- service, 2-5
- service information, 6-2
- shipment contents, 1-3
- shipment weight, 5-4
- shipping instructions, 7-6
- specifications, 5-2
- static-safe equipment
 - part numbers, 1-7
- storage conditions, 5-4
- switch
 - line, 4-4
 - printer/test set, 4-8
- switch, HP-IB address, 2-4
- switch repeatability, 6-7
- symbols and markings
 - instrument, 7-7

- T** temperature conditions, 5-4
- test data package, 5-6
- test port addresses, 3-3, 3-7
- test record card, 6-3, 6-8
- test set address, 3-3
- test set address switch, 2-4
- test set connection, 2-3
- test set ports, 4-4
- tests, performance, 6-3
- theory of operation, 6-22
- transmission connector, 4-5
- transmission measurements, 3-12
- transporting instructions, 7-6
- troubleshooting, 6-17

- U** uk6, 5-6
- unpacking the test set, 1-3

- V** voltage requirements, 1-4

- W** warning definition, 7-3
- weight, 5-4

— |

| —

— |

| —
